

SMZ1500

Nikon® **SMZ1500**

- 15:1 Zoom Ratio - World's largest on a stereo microscope
- Superior optics
- Ergonomically advanced
- Expanded accessory lineup
- Available OCC, Nikon's exclusive contrast technique for stereo microscopes



Stereoscopic Zoom Microscope



SMZ1500

Nikon's newest and most advanced stereo microscope.

Superior Optics

With the newly developed HR (high resolution) Apochromat objectives, higher resolution than ever before is possible in this type of microscope. In addition, the objectives and the zoom body correct for chromatic aberration and distortion simultaneously. This yields images in brilliant undistorted detail.

World's Largest Zoom Ratio

Makes changing lenses unnecessary allowing the operator to concentrate on observation.

Ergonomically Superior

The standard eyepiece tube is inclined 20 degrees to enable the operator to make observations without leaning forward. This minimizes neck fatigue and ensures comfortable operation even after hours of continued use. Other ergonomic features include a patented anti back-lash focusing mechanism that makes fine adjustment of focus easier and more accurate. Also available is up front fine focus, a patented design in which the operator can make fine focus adjustments with out removing his/her hand from the specimen slide.

Expanded Accessory Lineup

One of the keys to a powerful microscope is versatility. That's why the new SMZ1500 comes with a greatly expanded accessory lineup. This lineup includes three new diascopic stands, each equipped with up front fine focus and specially designed power supplies that keep temperatures at a low level, ideal for living specimens that are sensitive to temperature.

Oblique Coherent Contrast (OCC)

Nikon has introduced Oblique Coherent Contrast (option), a unique illumination technique designed to make observation of low contrast or transparent samples much easier. In the past, a compound microscope

equipped with phase contrast or differential interference contrast was required to see colorless biological specimens. But with OCC, viewing such specimens is now possible through a stereo microscope. OCC can reveal phase differences as small as 1/30 of a wavelength of light.

Specifications

Optical System	Parallel-optics zoom system
Total magnification	3.75X-540X (Depending on eyepiece and objective used.) (When coaxial episcopic illuminator is attached; 5.6x-506X)
Eyepiece tubes	P-BT Standard Binocular, P-BTL Low Eye-Level Binocular, P-BERG Tilting Binocular
Eyepiece inclination	20° (Standard Binocular and Low Eye-level Binocular), 0°-30° (Tilting Binocular)
Interpupillary distance adjustment	48-75mm (1.9-3.0in.)
Eyepieces (with diopter adjustment)	C-W10X (F.N.22), C-W15X (F.N.16), C-W20X (F.N.12.5), C-W30X (F.N.7)
Zoom range	0.75X-11.25X
Zoom ratio	15 : 1
Objectives	P-HR Plan Apo 0.5X, 1X, 1.6X; P-Plan Apo 1X (0.8X)
Illumination systems	P-IC12 Coaxial Episcopic Illuminator (12V-100W halogen) (Intermediate magnification is 1.5X.) P-FLA FL Epi FL Fluorescence Attachment C-Ni-150 Light Source with Heat Filter C-Dual Gooseneck Light Pipes C-Single Gooseneck Light Pipes Fiber Optic C-Ringlight A Fiber Optic C-Ringlight B C-Fluorescent Ringlight
Stands	C-PS160 Plain Stand C-DSS Diascopic Stand C-DSD Diascopic Stand C-BD Diascopic Bright/Darkfield Stand P-THS Teaching Head Stand
Photomicrographic/CCTV system	Nikon Photomicrographic SystemFX-III Series or CCTV camera can be attached through a Beam Splitter and Adapter.
Power consumption	Diascopic stands: 80W

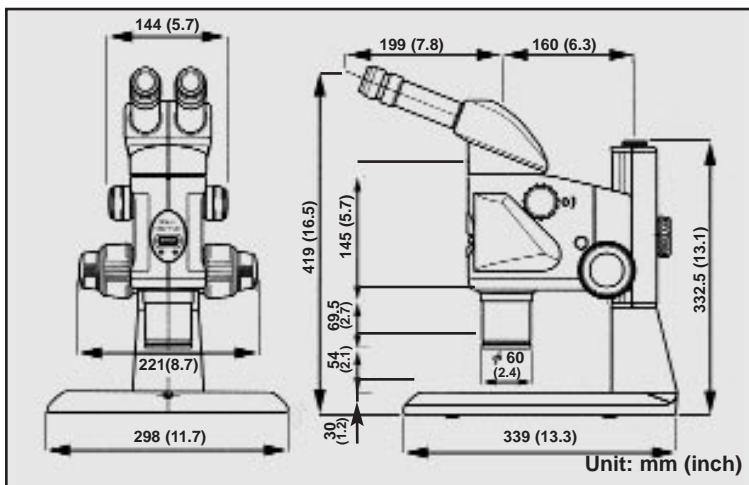

Nikon

NIKON INC. INSTRUMENT GROUP
1300 Walt Whitman Rd., Melville, NY 11747-3064, U.S.A.
Phone: 1-631-547-8500 / Fax: 1-631-547-0306
www.nikonusa.com

Specifications and equipment are subject to change without any notice or obligation on the part of the manufacturer. January 2000.

